

**MASTER**

**JOCKEY PUMP CONTROLLER**

**Model – JPCE**

**INSTRUCTION MANUAL**

---

**TABLE OF CONTENTS**

**Important Safety Information**..... Page 3

**General Description and Installation**..... Page 4

Model Number Construction..... Page 4

Standard Product Specifications..... Page 6

Installation..... Page 8

Connections..... Page 9

**Menu Functions**..... Page 13

Moving Through Screens..... Page 13

Function Changes with buttons..... Page 13

Startup Procedure and Check List..... Page 14

**Operating Instructions**..... Page 16

Maintenance..... Page 17

Replacement Parts List..... Page 18

Drawings:

    -Wiring Diagram

    -Piping Connection

Option and Modification Drawings

    -As needed

## **IMPORTANT SAFETY INFORMATION**



**WARNING - DANGER OF LETHAL ELECTRICAL SHOCK AND ARC FLASH HAZARD - USE APPROPRIATE PERSONAL PROTECTIVE EQUIPMENT (PPE) IN ACCORDANCE WITH NFPA 70E.**

**WARNING - TO PREVENT THE POSSIBILITY OF SERIOUS INJURY OR DEATH DUE TO AN ELECTRICAL FAULT, BE SURE THE DOOR(S) IS CLOSED AND LATCHED BEFORE CLOSING THE DISCONNECT SWITCH OR OPERATING THE CONTROLLER.**

**WARNING - THIS EQUIPMENT MUST ONLY BE SERVICED BY QUALIFIED ELECTRICAL PERSONNEL.**

**WARNING - DO NOT DEFEAT ANY INTERLOCKS OR SAFETY FEATURES OR EQUIPMENT OR CIRCUITRY.**

## GENERAL DESCRIPTION AND INSTALLATION

Master Model JPCE, Jockey Pump Controllers, are used in installations designed to NFPA-20, *Standard for the Installation of Stationary Fire Pumps for Fire Protection*. They are designed to maintain the system pressure so the fire pump does not start due to small leaks in the system.

Model JPCE controllers provide across-the-line (direct-on-line) full voltage starting for single or three phase motor driven jockey pumps.

### MODEL NUMBER CONSTRUCTION

<u>Model</u>	-	<u>Horsepower</u>	-	<u>Phase</u>	-	<u>Voltage Code</u>	-	<u>Modifications</u>
JPCE		1/3, 1/2, 3/4		1, 3		20 – 200v, 60hz		X (See table below)
		1, 1 1/2, 2, 3				21 – 208v, 60hz		
		5, 7 1/2, 10				22 – 220v, 50hz		
		15, 20 (varies				23 – 230v, 60hz		
		with voltage)				24 – 240v, 60hz		
						38 – 380v, 50hz		
						39 – 380v, 60hz		
						40 – 400v, 50hz		
						41 – 415v, 50hz		
						42 – 415v, 60hz		
						46 – 460v, 60hz		
						57 – 575v, 60hz		

#### X Modification Code Table

- AUD - Audible alarm with silence switch
- A1 - Pump run contact (one NO and one NC)
- A3 - Power Failure contact (one NO and one NC)
- DMD - Demand relay contact (one NO and one NC)
- EBH - Ethernet bulkhead adapter and cable
- L1 - Pump run LED pilot light (2L on drawing)
- L2 - Power On LED pilot light (1L on drawing)
- MP - MMP closed contact (one NC)
- RS - Remote Start input
- S1 - Service entrance rating
- SOA - Switch Off contact (one NO)
- TR - Trouble contact (one NO and one NC)
- TRA - Trouble contact (one NO and one NC) and LED pilot light
- W1 - 300 PSI, 316 SS pressure transducer and wet parts
- W7 - 500 PSI, pressure transducer and wet parts

Standard Automatic Functions

- Pressure Start
- Remote Start (delayed by sequence start)
- 2 second fixed Sequence Start Delay
- Minimum Run Timer (factory set to 2)
- Restart delay (factory set to 3 seconds)
- Failure to Start alarm
- Excessive Start alarm
- Overpressure alarm and shutdown (999 disables alarm)
- Conversion between PSI and BAR

**STANDARD PRODUCT SPECIFICATIONS**

Approvals – UL listed to ANSI/UL 508A

Voltage Rating – Controllers are designed for or it’s rated voltage, -15% and +10%.

Pressure Display Accuracy – Designed for +- 2% of rated voltage and current.

Short Circuit Current Rating – Standard controllers are rated for 5,000 symmetrical RMS amps at 200 vac to 480 vac. Higher ratings are available.

Horsepower Rating – Controller are designed to control the specific nameplated motor horsepower rating.

Service Factor – Controllers are designed for use with motors having a maximum Service Factor of 1.75 at 1/3 hp, 1.60 at 1/2 hp, 1.50 at 3/4 hp, 1.40 at 1 hp, 1.30 at 1 1/2 hp, 1.25 at 2 hp, and 1.15 at 3 hp and above.

Locked Rotor Code – Standard three phase and single phase controllers are designed for use with motors having a locked rotor KVA/HP code based on the following table:

Motor Voltage 200-600 vac			Motor Voltage 380-415 vac		
HP	Freq.	KVA/HP	HP	Freq.	KVA/HP
½	60	R	½	50	P
¾	60	P	¾	50	P
1	60	N	1	50	P
1 ½	60	M	1 ½	50	N
2	60	L	2	50	M
3	60	K	3	50	L
5	60	J	5	50	K
7 ½	60	H	7 ½	50	J
10	60	H	10 & up	50	H
15 & up	60	G			

Single Phase - Motor Voltage 230 vac

HP	Freq.	LRC
1/3	60	18
1/2	60	25
3/4	60	35
1	60	45
2	60	65
3	60	90
5	60	135

Remote Contacts – Optional voltage free contacts are rated for 6 amps (resistive) at 30 vdc, 6 amps (resistive) at 250 vac.

Pressure Rating – Standard controllers are rated for 300 PSI (20.7 BAR). Higher ratings are available.

Plumbing – Standard controllers are provided with brass fittings. Other materials are available.

Enclosure – Standard controllers are rated for NEMA type 2 or IP-31.

Ambient Temperature – Rated for operation in a 40C ambient. No direct sunlight is allowed on the enclosure.

## **INSTALLATION**

The jockey pump controller and all of its wiring and plumbing should be installed in accordance with the requirements given below and the wiring diagram located in the drawing section of this manual. It is designed to be installed in accordance with the requirements of NFPA-70, article 430, the *National Electric Code*, as well as any local requirements.

**LOCATION** - Controllers should be located as close as practical to the motors they control. It should also be located within sight of the motor and in an area free from dripping and spraying water.

**RATINGS** - Check that the system voltage and the motor nameplate voltage and horsepower ratings agree with the controller nameplate voltages and horsepower ratings before beginning installation.

**MOUNTING** - Controllers should be securely mounted and bolted to noncombustible surface or structure.

**CONDUIT ENTRANCE** - Conduit entrance can be made either through the top or bottom of the enclosure.

**CAUTION** - **FOREIGN METALLIC DEBRIS, SUCH AS DRILLING CHIPS, CAN CAUSE A DANGEROUS AND/OR DAMAGING ELECTRICAL FAULT WHEN THE EQUIPMENT IS ENERGIZED. BE SURE TO PROTECT ALL ELECTRICAL PARTS FROM METALLIC DEBRIS DURING INSTALLATION.**

Use appropriate conduit hub that matches the "Enclosure Type" as shown on the controller nameplate.

NOTE: If entering from the top, waterproof hubs are required for all installations



## CONNECTIONS

PIPING CONNECTIONS - A 1/4 inch nominal pressure sense line, typically made of brass, rigid copper or 300 series stainless steel, shall be connected to the incoming bulkhead connector located on the controller. The pressure sense line shall have two 3/32" orifices installed between the fire protection system and the bulkhead fitting. Secure this sense line as needed to prevent vibration or damage. For further installation details, consult NFPA-20 or refer to the Piping Diagram drawing located in the drawing section of this manual.

### POWER CONNECTIONS (Three Phase motors) –

**JPCE** - The three phase input power conductors are connected to the MMP line terminals L1, L2 & L3. The output motor wiring is connected to the bottom of the Main Contactor M load side terminal lugs T1, T2, and T3. Refer to the Wiring diagram for details.

For Single Phase motors, see the wiring diagram at the back of this manual.

MOTOR CIRCUIT CONDUCTORS - All motor circuit conductors must be sized according to the National Electric Code (NFPA-70) on a continuous duty basis. Insulation for these conductors should be chosen so it will not be affected by the surrounding environment and have an insulation temperature rating at least 90 degrees C.

The ampacity of the wire is based on 125% of the motor full load current (FLA) using the 60C column for 100 amps or less and the 75C column in field wiring table 310.15(B)(16) of the 2017 edition of the NFPA 70 for higher currents. Also, apply the appropriate correction factors in accordance with 310.15(B)(1) through 310.15(B)(7).

**CAUTION - BE SURE TO SECURE CONDUCTORS IN SUCH A MANNER SO THEY WILL NOT MOVE OR INTERFERE OR RUB AGAINST ANY COMPONENTS OR MECHANISMS IN THE CONTROLLER. PROTECT AGAINST CONTACT WITH SHARP EDGES OR CORNERS.**

NOTE: If modification code S1 is provided, the controller will be Suitable for Use as Service Entrance Equipment. A dual grounding lug is provided for the grounding electrode conductor and the grounded service conductor. No neutral connection is provided or needed. The controller is suitable for use on either three wire or four wire systems without the use of a neutral.

REMOTE ALARM CONNECTIONS - See the contact rating limitations on the wiring diagram.

1. Pump Running Signal (Mod Code A1) – Terminals numbered M1, M2, and M3 provide a form "C" set of contacts which transfer when the motor current is detected. Contacts on terminals M1 and M2 close in the alarm state, while contacts on terminals M2 and M3 open in the alarm state.
2. AC Power Failure Signal (Mod Code A3) – Terminals numbered P1, P2, and P3 provide a form "C" set of contacts which transfer when AC power is lost. Contacts on terminals P1 and P2 close in the alarm state, while contacts on terminals P2 and P3 open in the alarm state.
3. Pump Trouble Signal (Mod Code TR) – Terminals numbered T1, T2, and T3 provide a form "C" set of contacts which transfer when internal controller trouble exists. These are Low Voltage (80%), Failure to Start, Over Pressure, and Excessive Starting. Contacts on terminals T1 and T2 close in the alarm state, while contacts on terminals T2 and T3 open in the alarm state.
4. Low Zone Remote Start (Mod Code DMD) – Terminals numbered D1, D2, and D3 provide a form "C" set of contacts which transfer immediately when a start demand is received. Contacts on terminals D1 and D2 close in the alarm state, while contacts on terminals D2 and D3 open in the alarm state.
5. Jockey Pump Off Signal (Mod Code MP) – Terminals numbered J1 and J2 provide a form "A" set of contacts which transfer when the MMP operator is turned Off or the internal overload trips. Contacts on terminals J1 and J2 close in the alarm state.
6. Switch Off Signal (Mod Code SOA) – Terminals numbered S1 and S2 provide a form "A" set of contacts which transfer when the Auto-Off-Man switch is turned to the Off or Man position. Contacts on terminals S1 and S2 close in the alarm state.

REMOTE START INPUT (Mod Code RS)

Wire a normally open remote contact between terminals R1 and R2. Contacts close to start. See Circuit Wiring Table below for size and length of wire run.

Remote Start Circuit Wiring Table

<u>Wire Size</u>	<u>Wire Resistance Ohm/1,000 Ft.</u>	<u>12 vdc (50 Ohms)</u>	<u>24 vdc (250 Ohm)</u>
#12 AWG	1.588	15,700 Ft.	78,500 Ft.
#14	2.525	9,900	49,000
#16	4.016	6,200	31,000
#18	6.385	3,900	19,500
#20	10.15	2,500	12,500
#22	16.14	1,500	7,500
#24	25.67	940	4,700
#26	40.18	620	3,100

NOTE: Resistance and number of splices and contacts in circuit must be taken into consideration. A single splice may exceed the total resistance of 1,000 Ft. or more of wire.

MODBUS RTU CONNECTION

A RJ45 connector is provided on the control board inside the jockey pump controller. It is designed to connect directly to the RJ45 connector on the MASTER fire pump controller control unit (Modbus RTU connector). For compatibility, see the following table:

<u>Controller Description</u>	<u>HMI Manufacture</u>	<u>Software Version</u>
MC Electric	Proface	1.4
MC Electric with Mod. 48F or 82H	Magelis	7.2
MCV Electric	Magelis	7.2
EC or ECV Electric	Magelis	7.2
DMC Diesel	Proface	1.7
DMC Diesel with Mod. 48F or 82H	Magelis	5.0
DEC Diesel	Magelis	5.0

Note: The Data Recorder version is 5.4 for any electric or 6.7 for any diesel controller.

Once connected and enabled in the SERVICE menu, the jockey controller settings will be shown on the fire pump controller JPC screen. They can now be adjusted at the fire pump controller. Also, the fire pump controller will record the settings and history.

The jockey pump controller settings recorded on the fire pump controller are:

- Jockey Start
- Jockey Reset
- Jockey Restart
- Jockey Minimum Run Delay
- Jockey 24HR Over Cycle
- Jockey Starts/24HR
- Jockey Runtime-Hours
- Jockey Total Starts
- Jockey Delay Start
- Jockey VFD Mode

The jockey pump controller history recorded on the fire pump controller is:

Jockey Sequence Timer	On/Off
Jockey Auto mode	On/Off
Jockey Manual mode	On/Off
Jockey Security	On/Off
Jockey Running	On/Off
Jockey Remote Start	On/Off
Jockey Motor Run Timer	On/Off
Jockey Failure to Start	On/Off
Jockey Excessive Starting	On/Off
Jockey Trouble	On/Off
Jockey Comm Lost	On/Off
Jockey VFD mode	On/Off

## MENU FUNCTIONS

Moving through the menus:

- On power up, the Home screen is displayed.
- Press the Home button to always return to the Home screen.
- Press the Next button to move to the next screen
- Hold Next, then press DEC to move to the previous screen.
- In all menus, except the Home screen, use the INC or DEC buttons to change values. Hold the INC or DEC buttons down for 3 seconds to change values by 10.

Function changes with buttons:

- To change PSI to BAR
  - In the Home screen, press the HOME button for 3 seconds to change the pressure reading from PSI to BAR or visa versa.
- To enable sequence start
  - In the Home screen, press the INC button for 3 seconds to enable the “D” setting for a fixed 2 second sequence starting time delay.
- To calibrate the pressure
  - In the Home screen, press the INC and DEC buttons simultaneously for 3 seconds to access the pressure calibration screen.
  - Reduce the incoming pressure to zero, then Hold HOME for 3 seconds to set zero.
  - Press NEXT.
  - Increase the incoming pressure to the highest pressure possible, then Press INC or DEC to adjust the screen pressure to the calibrated gauge pressure reading.
  - Hold HOME for 3 seconds to set calibration.
  - Press INC and DEC to return to Home screen.
- To reset Motor Run Hours
  - In the Motor Run Hours screen, press INC and DEC simultaneously for 3seconds.
- To reset Starts
  - In the Starts/24Hr screen, press INC and DEC simultaneously for 3 seconds.
- To reset all settings to factory defaults, power-up while pressing the HOME button.
- To view software version
  - In the HOME screen, press the HOME button 3 times to view version number.

Note: To secure settings, move jumper J1 on the control board to position 2-3 (upper).

HOME MENU: Powers up to this screen. Displays actual pressure, Start and Stop pressures, and the Auto-OFF-Man mode. Press HOME three times to view the software version.

MOTOR RUN HOURS: Displays the total motor run hours to tenths of an hour. Press the INC and DEC buttons simultaneously for 3 seconds to clear the Run Hour history.

TRIP SETTING: Displays the Trip/Start setting. Press INC or DEC buttons to change.

RESET SETTING: Displays the Reset/Stop setting. Press INC or DEC buttons to change.

**MINIMUM RUN SETTING:** Displays the minimum run time. The factory default is 2. Press INC or DEC buttons to change.

**RESTART TIME SETTING:** Displays the restart delay time. The factory default is 3. Press INC or DEC buttons to change.

**MOTOR STARTS IN 24 HOURS SETTING:** Displays the number of Auto starts in a 24 hour period that will trip the Excessive Start Alarm. The factory default is 96. Press INC or DEC buttons to change. Press the INC and DEC buttons simultaneously for 3 seconds to clear the start history. Note: The EEPROM is written to every 15 minutes so depending on when the power is turned off, the last 15 minutes of start data may be lost. Set to 999 to disable (v2.0).

**OVERPRESSURE:** Displays the overpressure that will stop the pump and trip the alarm. Automatically resets 10 psi below trip point. The factory default is 999, which is disabled. Press INC or DEC buttons to change.

### **START UP PROCEDURE**

**WARNING - PERFORM THESE PRELIMINARY CHECKS BEFORE ENERGIZING ANY INPUT CONNECTION TO THE CONTROLLER.**

Make absolutely sure that the system (power supply) voltage, motor nameplate voltage and horsepower ratings correspond to the controller nameplate voltages and horsepower ratings.

Inspect for and remove any metal chips which may have fallen in the controller during installation.

Remove all shipping ties and packing material that may not yet have been removed.

Check all control wires for tightness.

Check that all connectors are seated and latched.

Check all connections in the power path of the motor and any Ground or Grounded conductors for tightness. Re-torque any loose connections to the component manufacturer's specifications. Contact Master Control Systems for additional information.

### **Start-up Checklist**

The following checklist is designed to verify basic operation and all field input and output connections. It is recommended for each new installation and the annual fire pump test.

**WARNING - TO PREVENT THE POSSIBILITY OF SERIOUS INJURY OR DEATH DUE TO AN ELECTRICAL FAULT, BE SURE THE DOOR IS CLOSED AND LATCHED BEFORE CLOSING THE MANUAL MOTOR PROTECTOR OR DISCONNECT SWITCH ON THE CONTROLLER.**

**CAUTION - BE SURE THE DISCHARGE VALVE IS CLOSED AND THE FIRE PUMP AND FIRE SPRINKLER SYSTEM ARE READY OPERATION.****I. ENERGIZING CONTROLLER**

- \_\_\_ A. Close and Latch the controller door(s).
- \_\_\_ B. Place the Auto-Off-Man switch in the OFF position
- \_\_\_ C. With the controller door closed, close the MMP Operator.
- \_\_\_ D. Check that the display begins powering up.
- \_\_\_ E. Check the Pump Rotation by jogging (bumping) the motor. Do this by momentarily changing the Auto-Off-Man switch to Man position. For 3 phase motors, if the pump runs backwards, open the MMP Operator or Disconnect Switch and have a qualified electrician change rotation by swapping two of the three motor leads on the (M) contactor output terminals.
- \_\_\_ F. Change the Auto-Off-Man switch to Man position to run the motor.
- \_\_\_ G. Change the Auto-Off-Man switch to Off position to stop the motor.

**II. ENERGIZING THE CONTROLLER FOR STAND-BY OPERATION**

- \_\_\_ A. Go to the Trip Setting menu and adjust the trip setting to the desired value.
- \_\_\_ B. Go to the Reset Setting menu and adjust the reset setting to the desired value.
- \_\_\_ C. Go to the Minimum Run Setting menu and set to the desired value.
- \_\_\_ D. Go to the Overpressure Setting menu and set to the desired value.
- \_\_\_ E. Change the Auto-Off-Man switch to Auto position.
- \_\_\_ F. Drop the pressure and check for a pressure start at the desired setting.
- \_\_\_ G. Verify it stops at the desired setting.

## **OPERATING INSTRUCTIONS**

**WARNING - TO PREVENT THE POSSIBILITY OF SERIOUS INJURY OR DEATH DUE TO AN ELECTRICAL FAULT, BE SURE THE DOOR IS CLOSED AND LATCHED BEFORE CLOSING THE MANUAL MOTOR PROTECTON OR DISCONNECT SWITCH OR OPERATING THE CONTROLLER.**

**EMERGENCY STOPPING – ROTATE THE MMP OR DS OPERATOR COUNTER CLOCK-WISE 90 DEGREES TO POWER OFF THE CONTROLLER AND STOP THE MOTOR.**

Energizing Controller: When energizing the controller for the first time after installation or after any service to the controller, motor, or motor wiring, follow the "Start-up Procedure" found earlier in this manual. For other cases, follow the Operating Instructions.

Stand-by Operation: The normal stand-by configuration for the controller is for the MMP Operator to be closed, the display to be On and the Auto-Off-Man to be in the Auto position.

De-energizing Controller: To de-energize the controller, rotate the MMP operator counter clockwise 90 degrees.

Manual Starting: Change the Auto-Off-Man switch to Man position.

Manual Electric Stopping: Change the Auto-Off-Man switch to Off position.



## MAINTENANCE



**WARNING - DANGER OF LETHAL ELECTRICAL SHOCK AND ARC FLASH HAZARD - USE APPROPRIATE PERSONAL PROTECTIVE EQUIPMENT (PPE) IN ACCORDANCE WITH NFPA 70E.**

**WARNING - THIS EQUIPMENT MUST ONLY BE SERVICED BY QUALIFIED ELECTRICAL PERSONNEL.**

On an annual basis, qualified electrical personnel should inspect the inside of the controller and check:

- All control wires for tightness
- That all connectors are seated and latched
- All connections in the power path for tightness. Re-torque any loose connections to the component manufactures' specifications. Contact Master Control Systems, Inc. for further information.
- For any indication of water marks on any of the components. Replace every component that has water marks on it.
- For any indication that the wire insulation is cracking, replace the controller.

If any operation of the controller does not function correctly, or the inspection reveals any of the above problems, contact Master Control Systems, Inc. for factory authorized service agent recommendations.

**REPLACEMENT PARTS LIST**

**JPCE Pressure Maintenance Controllers**

<i>DESIGNATION</i>	<i>DESCRIPTION</i>	<i>MCS PART NUMBER</i>
<b><i>Power Components</i></b>		
MMP	Manual Motor Protector	Consult Factory
MC	Motor Contactor	Consult Factory
<b><i>Control Components</i></b>		
Control Board	Control Unit with 2-line, 16 character display	801396
Transducer	300 PSI Pressure Transducer	306772
Transducer – W7	600 PSI Pressure Transducer	306773
F1, F2	Fuse Holder, 600 vac, 30 amp	Consult Factory
F1, F2	Fuse, 0.1 amp, Slow Blow (600 vac)	Consult Factory
F1, F2	Fuse, 0.2 amp, Slow Blow (380 – 480 vac)	Consult Factory
F1, F2	Fuse, 0.4 amp, Slow Blow (208 – 240 vac)	Consult Factory
F1	Fuse, 0.8 amp, Slow Blow (120 vac)	Consult Factory
F3	Fuse Holder, Inline, 50 vac, 10 amp	403243
F3	Fuse, 2.0 amp, 3AG, Slow Blow	201523
Auto-Off-Man	Selector Switch Operator, 22 mm	307451
	Contact Block Adapter	307453
	Contact Block Lever Lock	307454
	Contact Block, NO	307458
Navigation PB	Pushbutton, 16 mm	308044
Silence PB	Pushbutton, 22 mm	307444
AUD	Audible Alarm – Buzzer	403099
Alarm Relay-MR, PAR, TBL, DMD, MMP, SOA	24 vdc Alarm Relay, 1 form C	306811
<b><i>Transformers</i></b>		
	120 vac primary, 35 vac secondary	307891
	208-240 vac primary, 35 vac secondary	307893
	380-480 vac primary, 35 vac secondary	307895
	600 vac primary, 35 vac secondary	307896
<b><i>Mechanical Components</i></b>		
MMP Operator	MMP Operating Handle Door Kit	Consult Factory
EBH	Ethernet Bulkhead Adapter with Cap	402834/402749

NOTE: When ordering replacement parts, you must supply the Serial Number and Model Number of the Controller in which parts are to be used.

# Model JPCE Pump Motor Controller

# MASTER

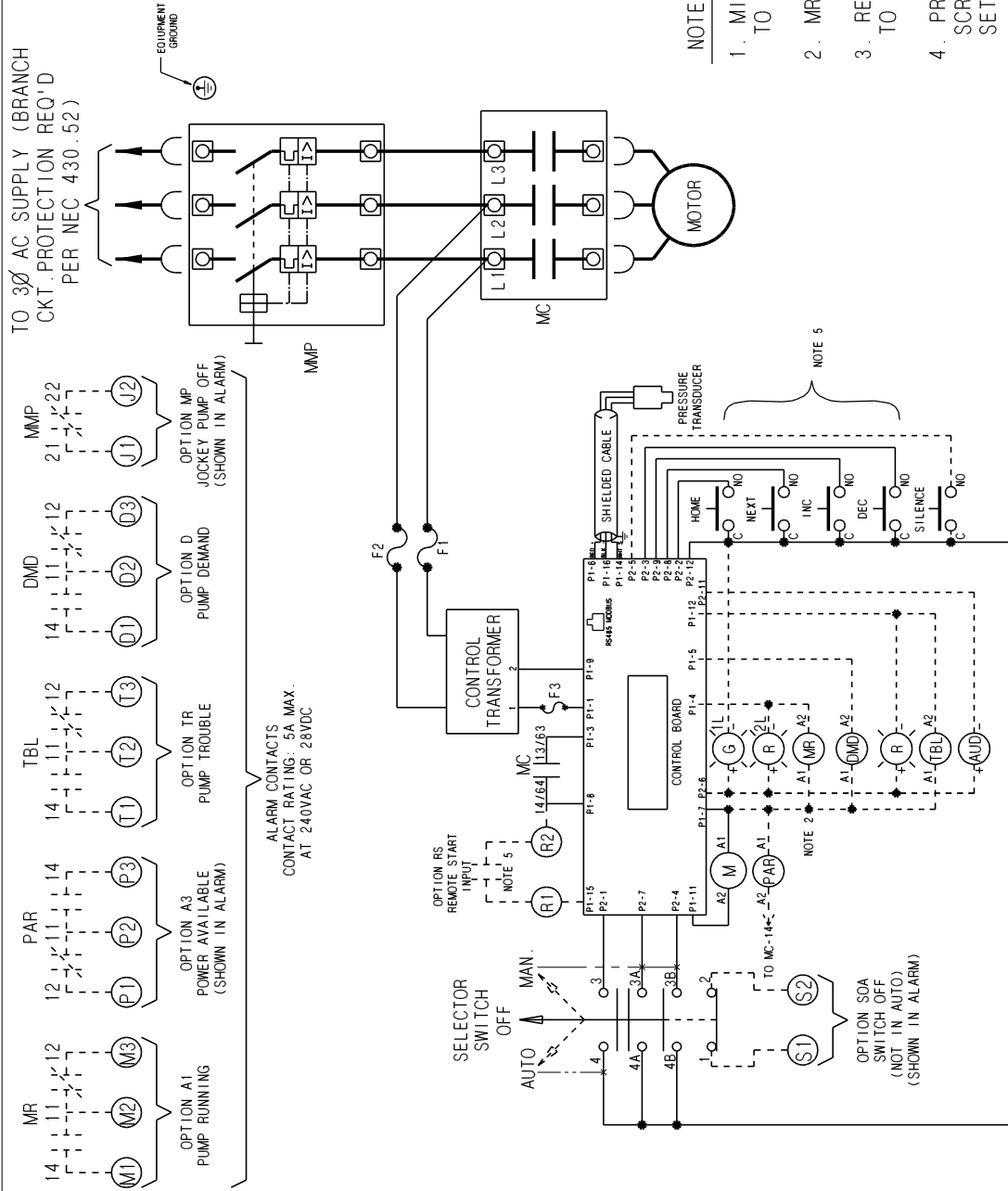

SYMBOL	DESCRIPTION
DS	DISCONNECT SWITCH
MMP	MANUAL MOTOR PROTECTOR
MC	MOTOR CONTACTOR CONTACTS
M	MOTOR CONTACTOR COIL
MR	MOTOR RUN RELAY (OPTION A1)
F1, F2	PRIMARY CONTROL CKT. FUSE
1L	POWER ON LAMP (OPTION L2)
2L	PUMP RUNNING LAMP (OPTION L1)
DMD	DEMAND RELAY
AUD	AUDIBLE ALARM
TBL	TROUBLE RELAY
---	OPTIONAL EQUIPMENT
—	FIELD WIRING

### NOTES:

1. MINIMUM RUN TIMER FACTORY SET TO 3 SECONDS. MAX SETTING 999 SECONDS.
2. MR SUPPLIED WITH OPT A1.
3. RESTART DELAY TIMER FACTORY SET TO 3 SECONDS. MAX SETTING 99 SECONDS.
4. PRESS 'NEXT' TO MOVE THROUGH SETUP SCREENS. PRESS 'INC/DEC' TO CHANGE SETTINGS. SEE MANUAL FOR MORE DETAILS.
5. MOMENTARY CONTACT. RUNS FOR MIN RUN TIME IF RESET PRESSURE IS SATISFIED. USE MAINTAINED CONTACT FOR CONTINUOUS RUNNING.



LISTED

# Model JPCE Pump Motor Controller

**MASTER**

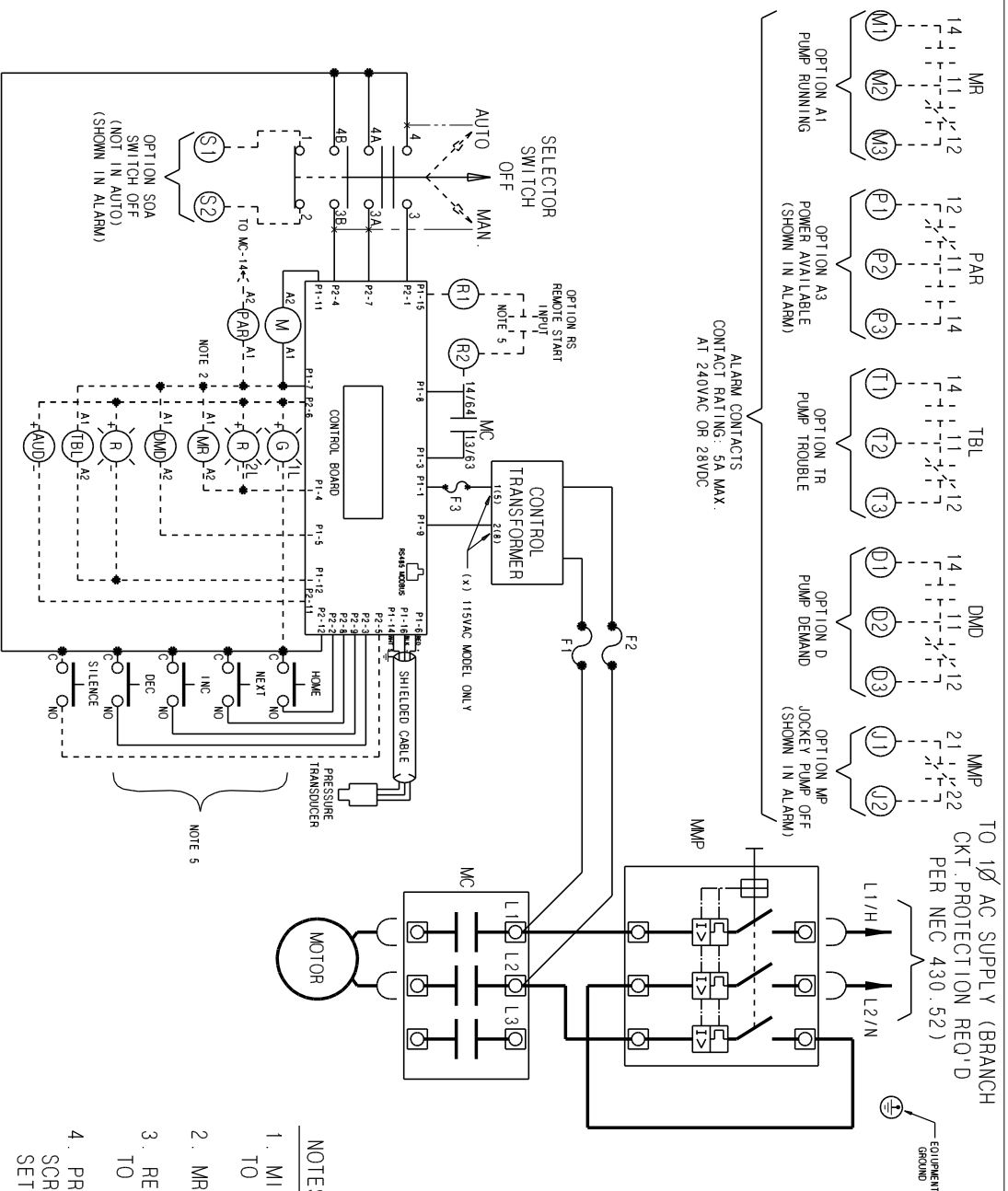

**NOTES:**

1. MINIMUM RUN TIMER FACTORY SET TO 3 SECONDS. MAX SETTING 999 SECONDS.
2. MR SUPPLIED WITH OPT A1.
3. RESTART DELAY TIMER FACTORY SET TO 3 SECONDS. MAX SETTING 99 SECONDS.
4. PRESS 'NEXT' TO MOVE THROUGH SETUP SCREENS. PRESS 'INC/DEC' TO CHANGE SETTINGS. SEE MANUAL FOR MORE DETAILS.
5. MOMENTARY CONTACT. RUNS FOR MIN RUN TIME IF RESET PRESSURE IS SATISFIED. USE MAINTAINED CONTACT FOR CONTINUOUS RUNNING.



LISTED





A3-060

MASTER CONTROL SYSTEMS, Inc.